



anovafurnishings.com
888.535.5005 tel

ASSEMBLY INSTRUCTIONS

Beacon Hill 3-Seat ADA Tables with Flat or Contour Seats

BH1830B- Bamboo with Contour Seats

BH1831B- Bamboo with Flat Seats

BH1830R- Recycled Plastic with Contour Seats

BH1831R- Recycled Plastic with Flat Seats

TOOLS NEEDED:

- Ratchet with 1/2" socket
- 1/2" Open end or box end wrench
- 5/32" Allen wrench
- Rubber mallet



Recycled Plastic with Contour Seats



Bamboo with Flat Seats

TABLE COMPONENTS:

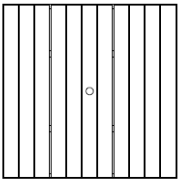

(1) Table Top

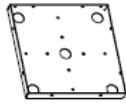

(1) Table Top Pan

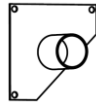

(1) Lower Leg Bracket

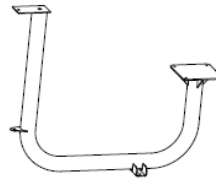

(3) Seat Supports

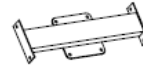

(3) Seat Mounts



OR



(3) Flat or Contour Seats

ASSEMBLY HARDWARE:

All hardware is stainless steel; extra hardware may be included.

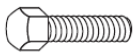

(18) 5/16" x 1" Hex Head Bolts



(30) 5/16" 18 Nylock Nuts



(48) 5/16" Flat Washers



(11) 1/4" x 1 1/2" Button Head Allen Bolts



(11) 1/4" Flat Washers



(3) Plastic Plugs



(12) 5/16" x 1" Flat Head Socket Cap Screws

ASSEMBLY:

The assembly is a two-person operation.

1. Inspect the shipping container contents for damage and to determine that all components and hardware are present.
2. Assemble the table over the shipping packaging or padded work area to avoid scratching the product.

Note: Before assembling the nuts to the bolts, it is recommended that a light oil or petroleum jelly be applied to the screw threads.

3. Open the hardware package and find the three black plastic plugs. Insert a plug in the hole on the bottom of each of the seat supports. Use the rubber mallet to seat the plugs.

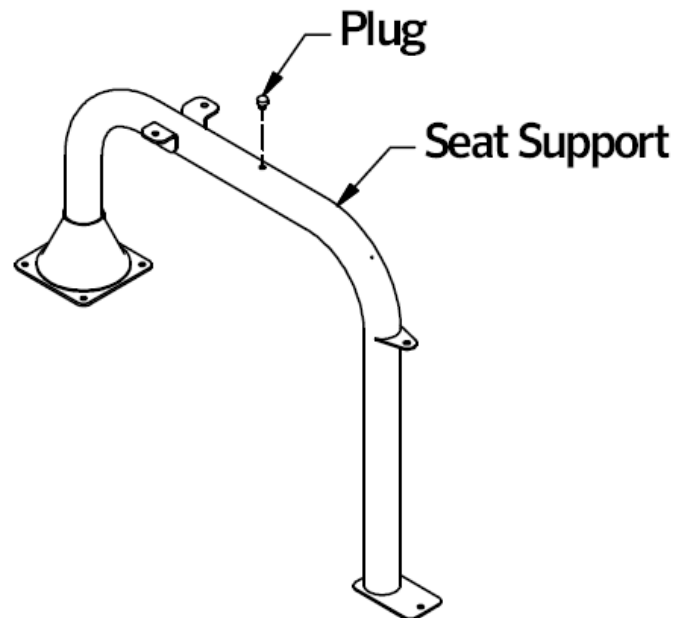

4. Locate two seat supports and the lower leg bracket. Position the seat supports so that they will be opposite each other when fastened to the lower leg bracket. Install 5/16" flat washers on 5/16" x 1" hex head bolts and insert the bolts through the appropriate mounting holes in the lower leg bracket and into the lower mounting holes in the seat supports. Place 5/16" flat washers and 5/16" Nylock nuts on the end of the bolts and tighten finger tight.

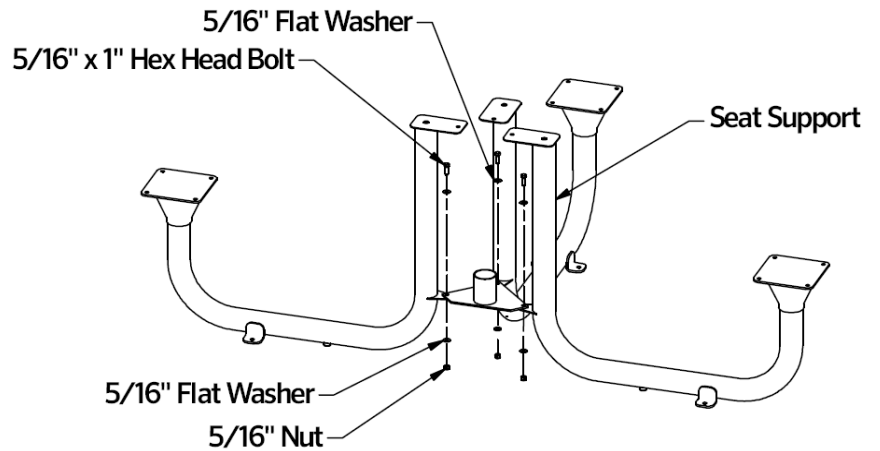

5. Position the remaining seat support so that it aligns with the remaining mounting hole in the lower leg bracket. Attach the seat support to the lower leg bracket using a 5/16" x 1" hex head bolt with 5/16" flat washers on the top and bottom and a 5/16" Nylock nut to secure. Leave the hardware finger tight until after the table top pan is secured (step 7).

6. Locate the table top pan and place it on top of the platform created by the raised end of the seat supports. Adjust the placement of the table top pan until one set of mounting holes in the pan aligns with the corresponding set of mounting holes in one of the seat supports.

Place a 5/16" flat washer on the end of one of the 5/16" x 1" hex head bolts and insert the bolt through the pan mounting hole in the inner bolt circle and through the hole in the support. Fasten the bolt using a 5/16" flat washer and a 5/16" Nylock nut on the bottom of the bolt.

Leave the bolt and nut finger tight. Repeat this for the remaining two 5/16" hex head bolts. You may have to adjust the seat supports or the table top pan in order to get the mounting holes to align.

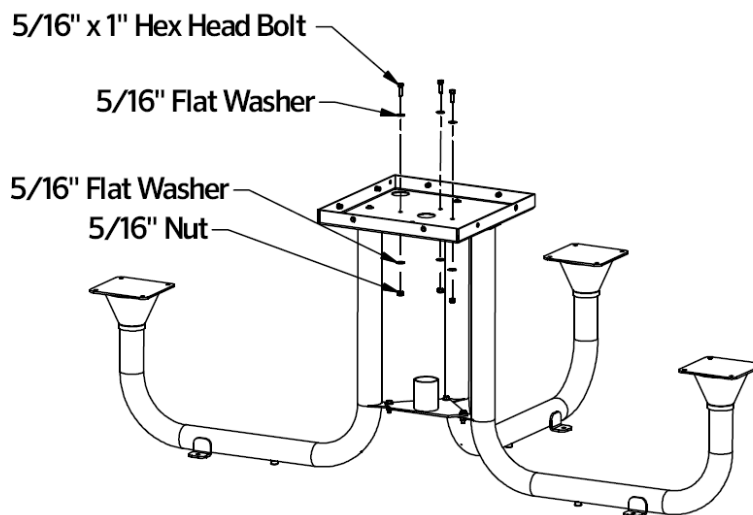

- Place a 1/4" flat washer on the end of one of the 1/4" x 1 1/2" button head Allen bolts and insert the bolt through one of the pan mounting holes in the outer bolt circle and into the corresponding threaded hole in the seat support. Leave the bolt finger tight.

Repeat this for the remaining two 1/4" x 1 1/2" button head Allen bolts in the top of the table top pan. You may have to adjust the seat supports or the table top pan in order to get the mounting holes to align.

After all the button head Allen bolts are installed, tighten all of the hardware in the lower leg bracket and at the table top pan.

Note: Be careful not to over tighten the button head Allen bolts; the inserts they thread into could unseat and begin to spin with the bolt.

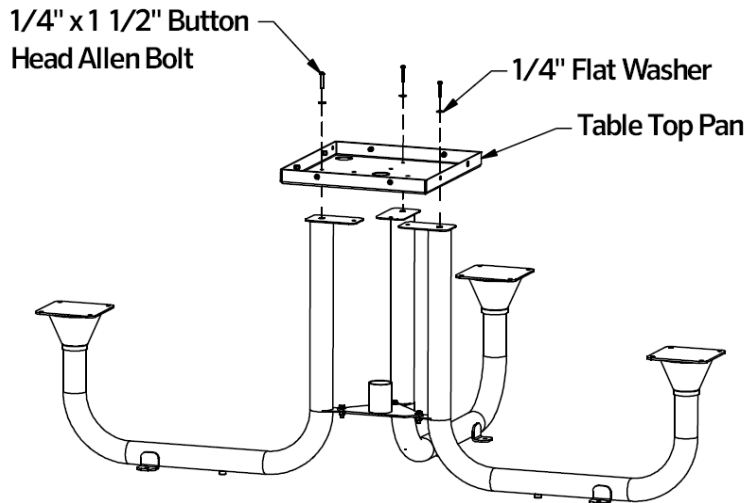

- Locate one of the seat mounts. Position the seat mount on the lower end of one of the seat supports so that the mounting holes in the seat mount aligns with the mounting holes in the seat support mounting plate. Install four 5/16" x 1" hex head bolts with 5/16" flat washers (top and bottom) and 5/16" Nylock nuts. Install the remaining seat mounts in the same manner.

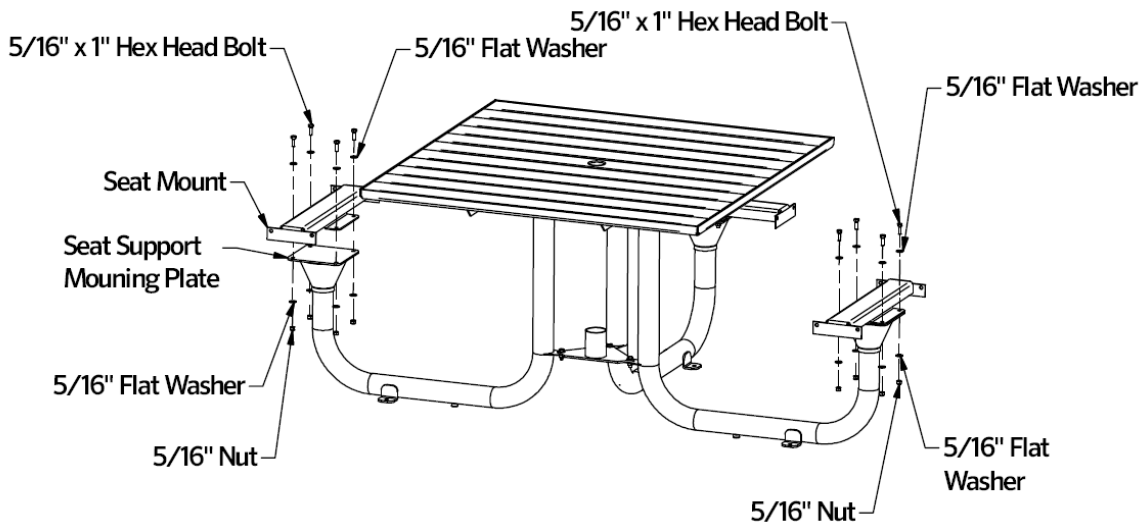

- Lift the table top and move it over the top of the table top pan. Rotate the table top until the square frame on the bottom of the table top matches the orientation of the table top pan. Carefully lower the table top down onto the table top pan.

Secure the table top to the table top pan using the remaining eight 1/4" x 1 1/2" button head Allen bolts (two bolts on each side) with a 1/4" flat washer on each of the bolts. You may have to lift the table top slightly to get the holes to align.

Leave the bolts finger tight until all of the bolts are started, then use the 5/32" Allen wrench to tighten the bolts.

Note: Be careful not to over tighten the bolts; the inserts they thread into could unseat and begin to spin with the bolts.

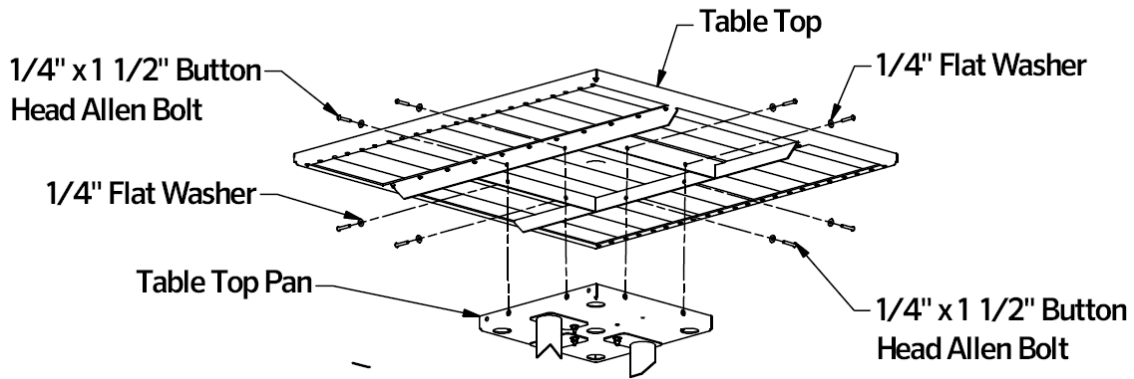

- Place one of the seats (flat or contour) over one of the seat mounts. Use four 5/16" x 1" flat head socket cap screws with 5/16" flat washers (inside and outside) and 5/16" Nylock nuts. Install the remaining seats in the same manner.

Note: Extra hardware may be included.

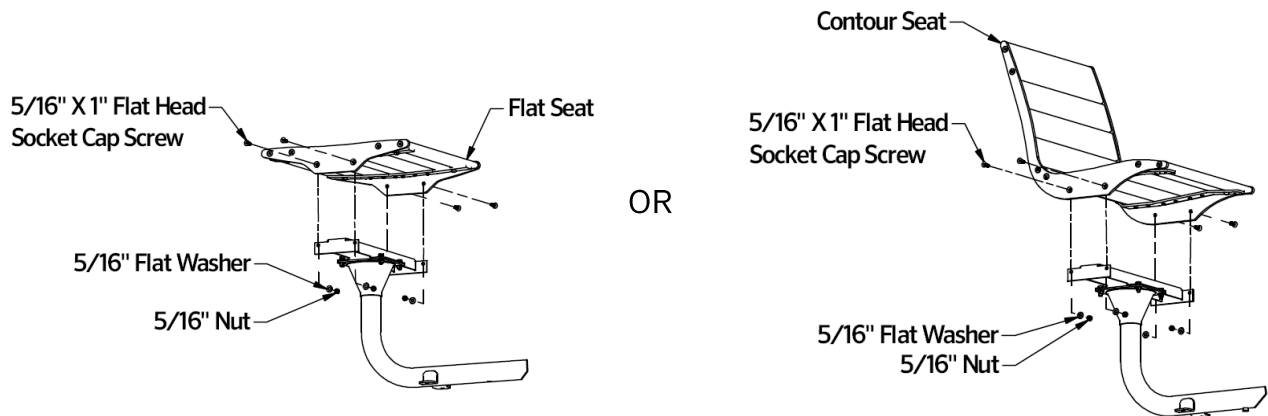

- Move the table to the location where it will be used.
Note: Tables must be surface mounted for stability and to comply with warranty and federal ADA regulations.

- After two weeks, retighten all hardware.

 WARNING	<ul style="list-style-type: none"> Furniture must not be used other than for its intended purpose and should be inspected regularly for loose, missing, or broken hardware, and general instability. Furniture that is damaged or appears to be unstable must be removed from service and be repaired or replaced. Repairs must be made using only factory authorized parts and methods.
---	---

CARE AND MAINTENANCE	<ul style="list-style-type: none"> Do not drag the assembled unit across any surface. This product requires periodic cleaning with a sponge and a solution of mild detergent and water to remove surface dirt. Do not clean with a solvent or petroleum based products.
-----------------------------	--