



ASSEMBLY INSTRUCTIONS

L1535 40-Gallon Receptacle

anovafurnishings.com
888.535.5005 tel

TOOLS NEEDED:

- 7/16" Open-end or Box-end Wrench
- Flat Blade Screwdriver



RECEPTACLE COMPONENTS:

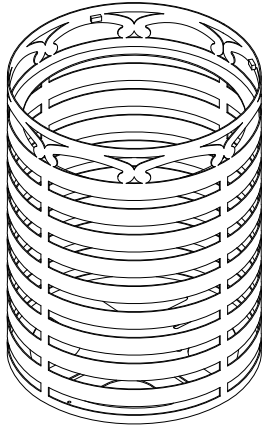

1 x
Receptacle Body

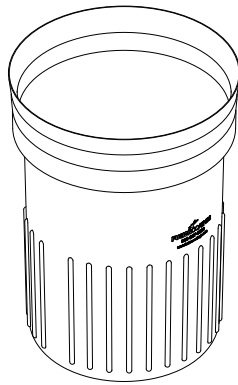

1 x
Plastic Liner

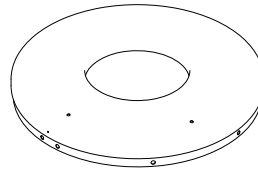

1 x
Spun Steel Top

ASSEMBLY HARDWARE:

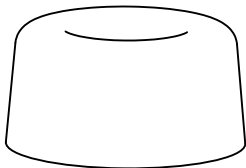

3 x
Rubber Foot

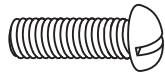

3 x
1/4 - 20 X 3/4"
Round Head Screw



3 x
1/4 - 20
Flange Nut

ASSEMBLY:

Note: Even if installing the Receptacle as a surface mount, it is required to install the Rubber Feet to maintain the satisfaction guarantee and as a precaution against corrosion due to standing water, salts, or other corrosive elements.

1. Inspect the shipping container contents for damage and to determine that all components and hardware are present.
2. Place the Receptacle Body upside down on the packaging cardboard or other soft surface to avoid scratching the product.

NOTE: the three outer holes on the bottom of the Receptacle are intended for mounting the Rubber Feet. The four inner holes are designed for use in surface mount applications.

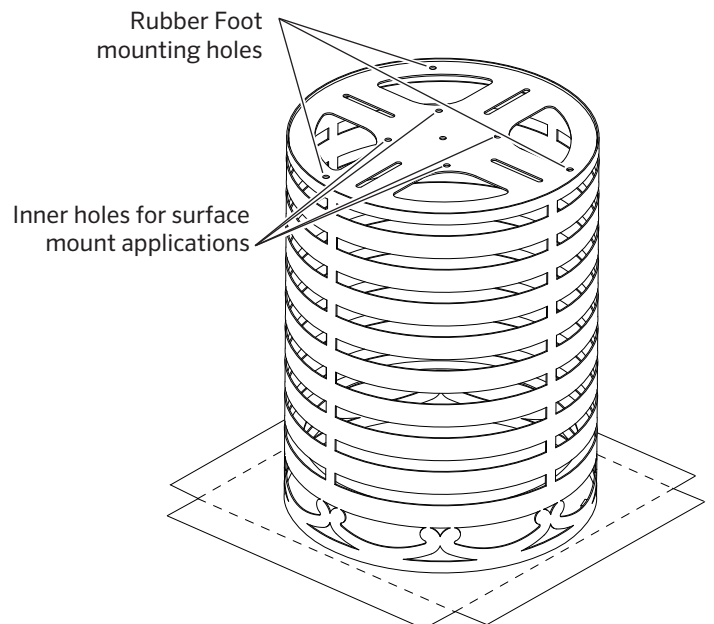

3. Push the threaded end of one of the Screws into the hole in the counterbored side of one of the Rubber Feet. Insert the Screw into one of the Foot mounting holes on the bottom of the Receptacle.

Place a Flanged Nut on the end of the Screw on the inside of the Receptacle Body. Use the Wrench to hold the Nut still while tightening the screw with the screwdriver. This will protect the powdercoat finish inside the Receptacle Body.

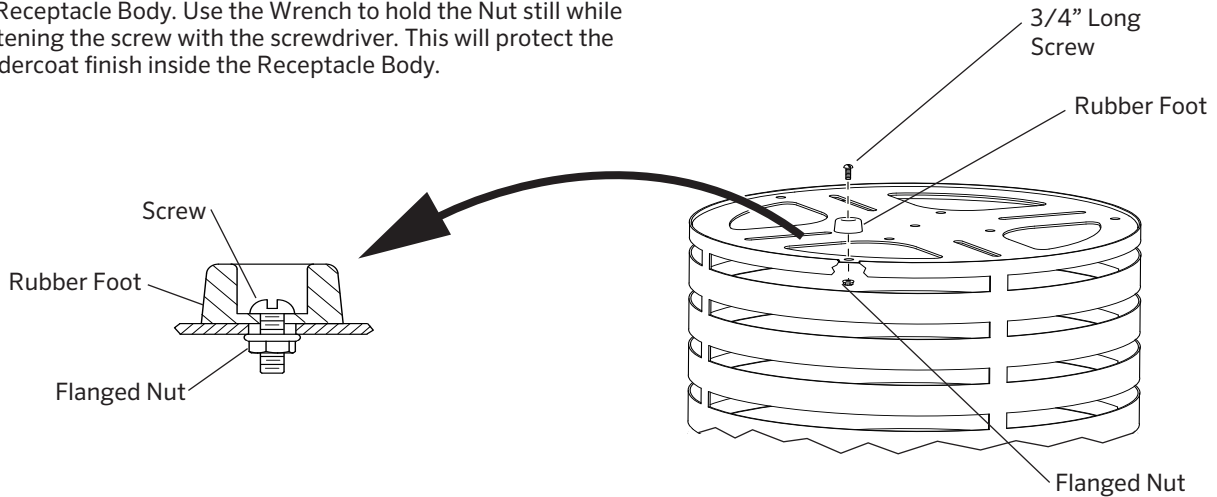

4. Repeat Step 3 for the remaining two Rubber Feet.
5. Turn the Receptacle Body right side up.
6. Place the Plastic Liner inside the Receptacle Body with the opening facing up.
7. Place the Spun Steel Top over the top of the Receptacle Body.
8. Move the assembled Receptacle to the desired location.
9. Retighten the hardware two weeks after the initial assembly.



WARNING

- Furniture must not be used other than for its intended purpose and should be inspected regularly for loose, missing, or broken hardware, and general instability.
- Furniture that is damaged or appears to be unstable must be removed from service and be repaired or replaced.
- Repairs must be made using only factory authorized parts and methods.

CARE AND MAINTENANCE

- Do not drag the assembled unit across any surface.
- This product requires only periodic cleaning with a sponge and a solution of mild detergent and water to remove surface dirt. Do not clean with a solvent or petroleum based products.



211 North Lindbergh Blvd.
St. Louis, MO 63141

tel: 888.535.5005
web: anovafurnishings.com