



anovafurnishings.com  
888.535.5005 tel

# ASSEMBLY INSTRUCTIONS

- D1111 Square
- D1113 Round
- D1113NH Round
- D6013 Square
- D6013COM Square Commerative
- F1111 Square
- F1113 Round
- F1117 Square
- F1118 Octagonal
- F1121 Octagonal
- L1111 Square



## TOOLS NEEDED:

- 1/2" Open-end or Box-end Wrench
- Ratchet Wrench with 1/2" Socket
- Level
- Rubber Mallet or Hammer

## TABLE COMPONENTS:

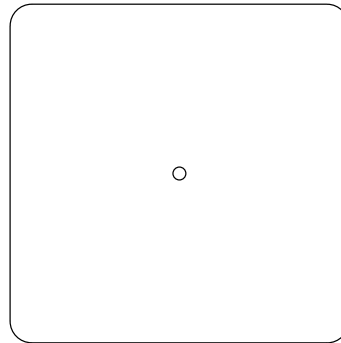

1 x Tabletop  
Square, Round, or  
Octagonal



4 x Seat  
(Traditional or  
Rolled Edge)

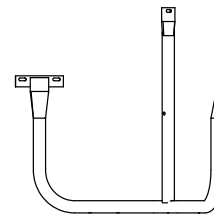

4 x Leg

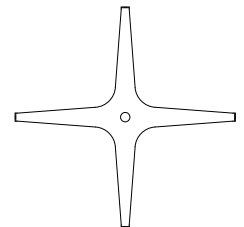

1 x Cross Brace

## ASSEMBLY HARDWARE:

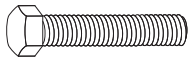

4 x  
5/16" X 2.25" Long  
Hex Head Bolt



24 x  
5/16"  
Flanged Hex Nut

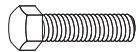

20 x  
5/16" X 1.25" Long  
Hex Head Bolt



48 x  
5/16"  
Washer



8 x  
Plastisol Plug

## ASSEMBLY:

The assembly is a two-person operation.

1. Inspect the contents for damage and to determine that all components and hardware are present.
2. Place the tabletop upside down on the shipping plastic over the packaging or other soft surface to avoid scratching the product.

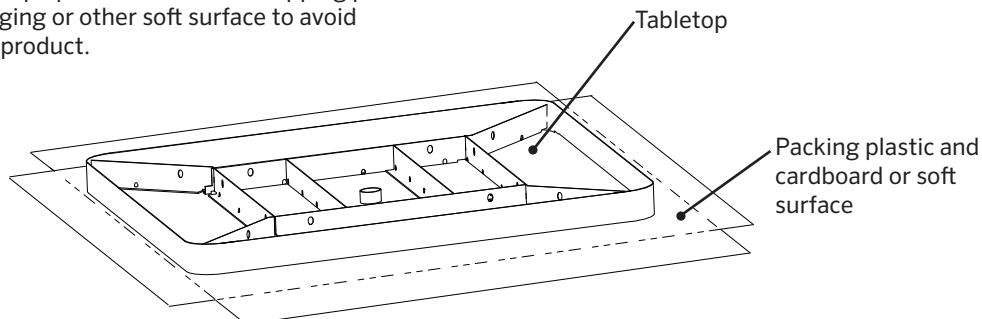

- Place one of the Table Legs next to the tabletop frame support as shown. When viewing down the frame support on the outside of the table, the Leg should go on the right side of the frame support. Put a Washer on one of the 1.25" long Bolts and insert the Bolt through the Leg and frame support with the bolt head toward the outside of the Tabletop. Install a Washer and Nut to the Bolt and hand tighten, leaving the Nut finger-tight. Repeat this step for each of the three remaining Legs.

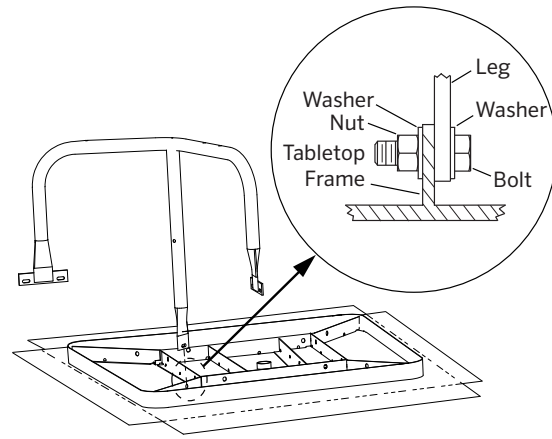

- After all the Legs are attached (only two are shown here for clarity), install the Cross Brace. Put a Washer on one of the 2.25" long Bolts and insert the Bolt through the Leg and Cross Brace with the bolt head toward the outside of the Tabletop. Install a Washer and Nut to the Bolt and hand tighten, leaving the Nut finger-tight. Repeat this step for each of the three remaining Legs.
- Use a Rubber Mallet or Hammer to seat the Plastisol Plugs into the holes on the bottom of each Leg.

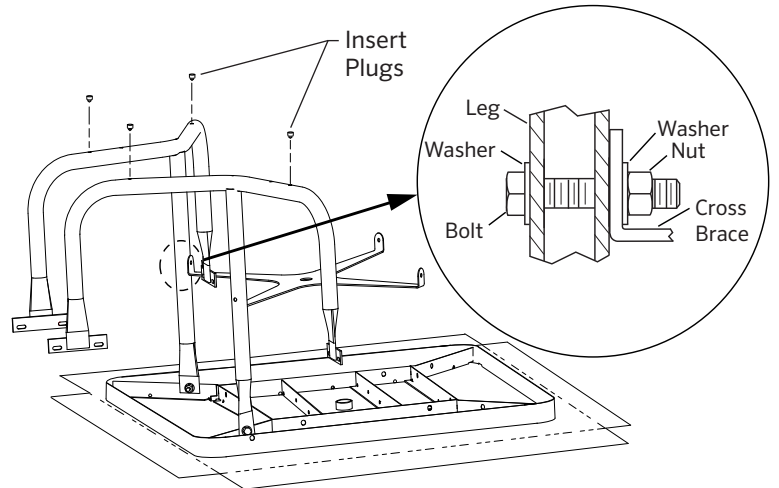

- Position a Seat upside-down next to one of the Legs as shown. The leg brackets attach to the outside of each of the seat frame cross-members. Put a Washer on one of the 1.25" long Bolts and insert the Bolt through the leg bracket and seat frame cross-member with the bolt head toward the outside of the Seat. Install a Washer and Nut to the Bolt and hand tighten, leaving the Nut finger-tight. Repeat this step for each of the three remaining mounting holes in that Seat. Install the three remaining Seats in the same manner.
- Turn the table right side up and tighten the table frame hardware while checking with a Level; minor adjustments can be made while tightening the hardware to make the Tabletop level.
- Tighten the hardware on each of the seat frames while checking the Seat with a Level; minor adjustments can be made while tightening the hardware to make the Seat level.
- Retighten all hardware two weeks after initial assembly.

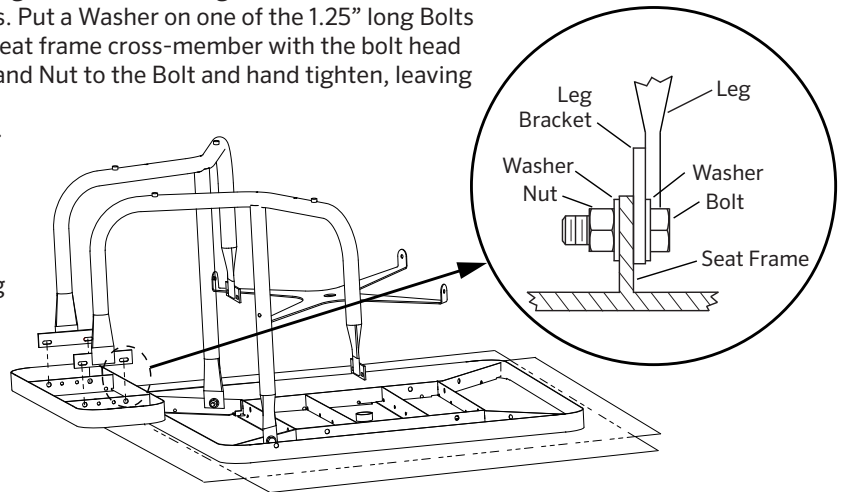

**WARNING**

- Furniture must not be used other than for its intended purpose and should be inspected regularly for loose, missing, or broken hardware, and general instability.
- Furniture that is damaged or appears to be unstable must be removed from service and be repaired or replaced.
- Repairs must be made using only factory authorized parts and methods.

**CARE AND MAINTENANCE**

- Do not drag the assembled unit across any surface.
- This product requires only periodic cleaning with a sponge and a solution of mild detergent and water to remove surface dirt. Do not clean with a solvent or petroleum based products.



211 North Lindbergh Blvd.  
St. Louis, MO 63141

tel: 888.535.5005  
web: [anovafurnishings.com](http://anovafurnishings.com)