



anovafurnishings.com
888.535.5005 tel



F1060

ASSEMBLY INSTRUCTIONS

Victory Bench, Portable Frame

- F1060** - 6' Expanded Steel Bench, Traditional Edge
- F1063** - 8' Expanded Steel Bench, Traditional Edge
- F3044** - 4' Expanded Steel Deep Seat Bench, Traditional Edge
- F1338** - 6' Expanded Steel Deep Seat Bench, Traditional Edge
- F3050** - 8' Expanded Steel Deep Seat Bench, Traditional Edge
- D1060** - 6' Perforated Steel Bench, Traditional Edge
- D1060COM** - 6' Perforated Steel Plaque Bench, Traditional Edge
- D1063** - 8' Perforated Steel Bench, Traditional Edge
- F1050** - 6' Expanded Steel Bench, Rolled Edge
- F1053** - 8' Expanded Steel Bench, Rolled Edge
- C1060** - 6' Perforated Steel Custom Bench, Traditional Edge
- C1063** - 8' Perforated Steel Custom Bench, Traditional Edge
- C1060BB** - 6' Perforated Steel Buddy Bench, Traditional Edge

TOOLS NEEDED:

- Rubber Mallet
- 1/2" Open-end or Box-end Wrench
- Ratchet with 1/2" Socket
- Level

ASSEMBLY HARDWARE:

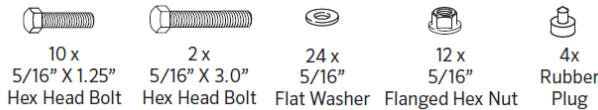

BENCH COMPONENTS:

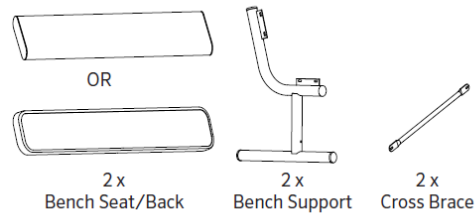

ASSEMBLY:

NOTE: Before assembling the Nuts to the Bolts, it is recommended that a light oil or petroleum jelly be applied to the Bolt threads.

1. Inspect the shipping container contents for damage and to determine that all components and hardware are present.
2. Locate the two Bench Supports and lay them out on the Packaging cardboard or other soft work space to avoid scratching the product. Remove the four Rubber Plugs from the hardware package. Use the Rubber Mallet to seat two Plugs into the bottom of each Bench Support.
3. Place one of the Bench Seats on the shipping packaging or other soft work space. Position one of the Bench Supports near the end of the Seat.
4. Align the mounting holes in the bracket on the Bench Support with the mounting holes in the Bench Seat frame. Install a Washer onto one of the 1.25" long Bolts and insert the Bolt through both parts, with the Bolt head toward the outside surface of the Bench Seat. Install a Washer and Flanged Nut on the inside end of the Bolt.

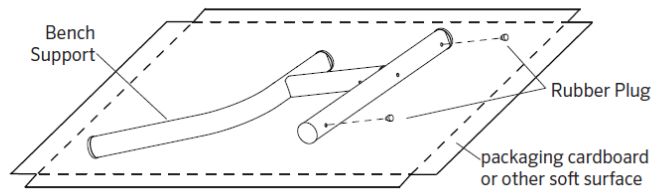

NOTE: Installing the Bolt in this direction reduces the risk of scratching during use.

Leave the hardware finger tight so that adjustments can be made during assembly and leveling.

Install a Bolt and Washer through the other set of mounting holes in that end of the Bench Seat frame and Bench Support bracket and install a Washer and Flanged Nut. Again, leave the hardware finger tight.

5. Attach the other Bench Support to the Bench Seat in the same manner, installing the 1.25" long Bolts from the outside inward. Leave the hardware finger tight.

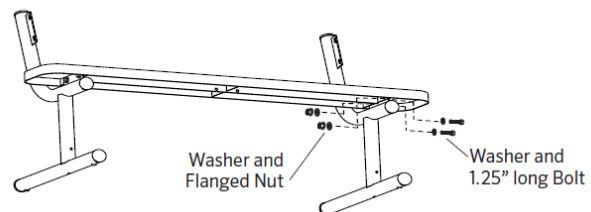
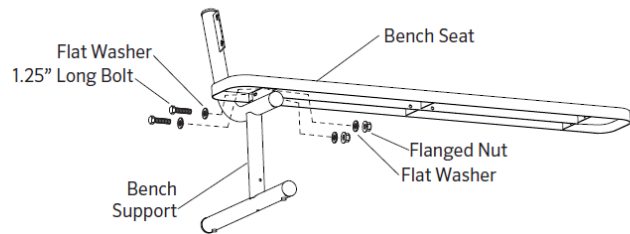

6. Locate one of the Cross Braces. Align the mounting hole in one end of the Cross Brace with the hole near the bottom of one of the Bench Supports. Install a Washer onto one of the 3" Bolts and insert the Bolt through the Cross Brace and the Bench Support. Put a Washer and Nut on the end of the Bolt and tighten finger tight.

Swivel the other end of the Cross Brace up to the Bench Seat so the mounting hole in the end of the Cross Brace aligns with the mounting hole in the frame of the Bench Seat. Insert one of the 1.25" Bolts with Washer through the Seat frame and then the Cross Brace. Secure the Bolt with a Washer and Nut. Leave the hardware finger tight.

Install the other Cross Brace in the same manner.

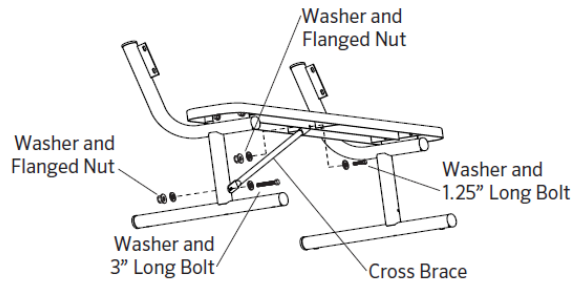

Note: the Cross Brace is designed to attach to the front of the Seat Support and to the back of the Seat frame.

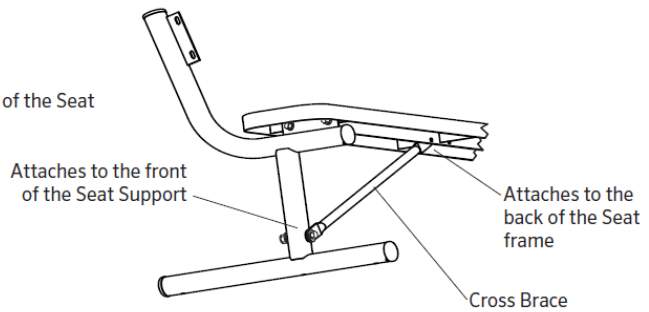

7. The remaining Bench Seat becomes the Bench Back. Align the mounting holes in the Bench Back with the holes in the appropriate Bench Support. Install a Washer onto one of the 1.25" long Bolts and insert the Bolt through both parts, with the Bolt head toward the outside surface of the Bench Support. Install a Washer and Nut on the inside end of the Bolt.

Leave the hardware finger tight so that adjustments can be made to the Bench Back.

Install a 1.25" long Bolt with Washer through the other set of mounting holes in that end of the Bench Support and Back and install a Washer and Nut on the end of the Bolt. Again, leave the hardware finger tight.

8. Attach the other end of the Bench Back to the other Bench Support in the same manner. Leave the hardware finger tight.
9. Tighten the Cross Brace hardware using the Open End or Box End Wrench and Ratchet Wrench while checking the Seat with a Level; minor adjustments can be made while tightening the hardware to make the Seat and Supports square.
10. Continue tightening the rest of the Bench hardware while checking the Seat with a Level.
11. Move the assembled Bench to the desired location.
12. Retighten hardware two weeks after initial assembly.

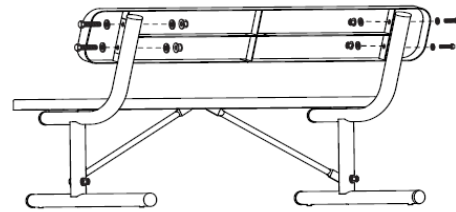

WARNING

- Furniture must not be used other than for its intended purpose and should be inspected regularly for loose, missing, or broken hardware, and general instability.
- Furniture that is damaged or appears to be unstable must be removed from service and be repaired or replaced.
- Repairs must be made using only factory authorized parts and methods.

CARE AND MAINTENANCE

- Do not drag the assembled unit across any surface.
- This product requires only periodic cleaning with a sponge and a solution of mild detergent and water to remove surface dirt. Do not clean with a solvent or petroleum based products.