



211 North Lindbergh Blvd.
 St. Louis, MO 63141
 888.535.5005 tel
 314.754.0835 fax
 specify@anovafurnishings.com
anovafurnishings.com



F1338 VICTORY FLAT BENCH WITH BACK

6' expanded metal bench with deep flat seat and back, traditional edge, and portable mount legs

Accessories

- 1-Hole Hold Down Kit **A2375**
- 2-Hole Hold Down Kit **A2376**

Material

The bench is 72.25" long with an extra wide 15.25" flat bench seat and back. The seat and back are made of 3/4 #9 expanded steel with a diamond shaped pattern and feature a traditional edge. The seat and back are protected by Fusion Advantage™, a plastisol coating with an average .125" thickness and a high-gloss powder coat. The bench seat will support 200 lbs per linear foot.

The legs are made of 2.38" O.D. steel tubing protected by a fade resistant powder coat finish featuring a state of the art primer proven to prevent rusting. The legs feature feet made of 2.38" O.D. steel tubing that are 27" long that provide a sturdy support and portable mount for flexibility in placement.

Finish

Fusion Advantage is a heat fused plastisol coating that creates an impervious rustproof barrier and resists UV deterioration, mildew, staining and fading.

The finish has been tested to the requirements of ASTM E1354 and is determined to be in compliance with California Uniform Fire Code 1103.2.1.4.2.

A state of the art primer is applied to all of the under supports, providing extreme rust fighting protection and durability. Treated components exceed the industry standard by 34% in testing by independant sources.

Color

See website or sales representative for color choices.

Assembly

The bench requires some assembly. Stainless steel assembly hardware is included.

Maintenance

The product is virtually maintenance-free and requires only periodic cleaning with a sponge and a solution of mild detergent and water to remove surface dirt. Do not clean with solvent or petroleum based products.

Warranty

20-year limited structural warranty with 7-year finish warranty from the date of purchase. See full details on multi-year warranties for components at www.anovafurnishings.com/warranty.aspx.

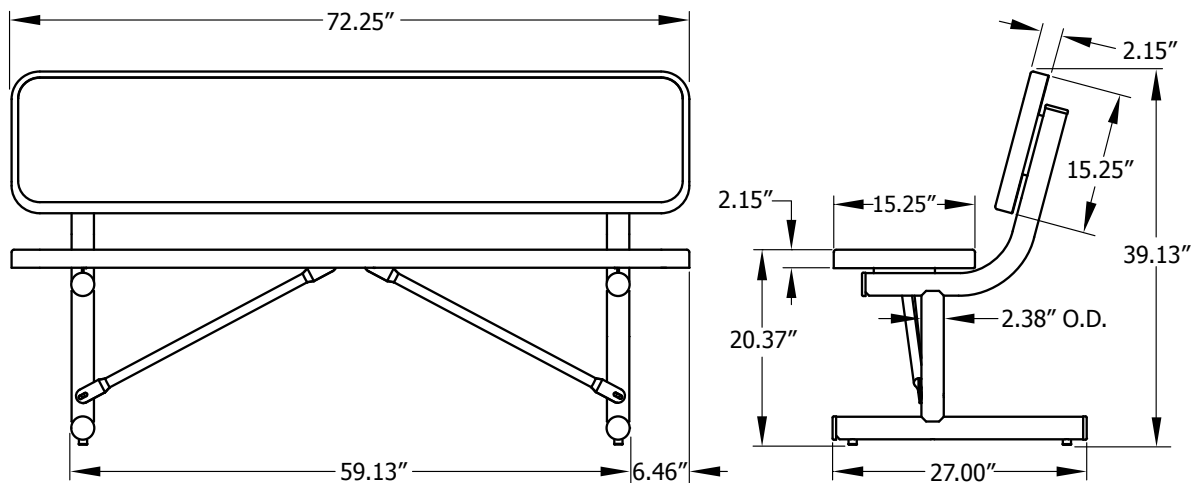

Shipping Information

Unit Wt.	Unit Shipping Wt. UPS	Unit Shipping Wt. Truck (1+ Units)	Unit Ship Size w/Pallet	Max Units per Pallet	Pallet Wt. (74" x 32")	Total No. Pkgs	Shipping Class
132 lbs	NA	141 lbs/unit	18 cu. ft.	6	100 lbs	2	70